



**PT. SUMBER
ARTHO
INDORAYA**

**SMART
ACCOUNTABILITY
INTEGRITY**
COMPANY PROFILE

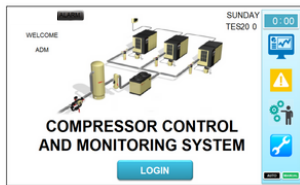


GENERAL CONTRACTOR MECHANICAL AND ELECTRICAL - AIR COMPRESSOR AND INSTRUMENT SYSTEM.
GENERAL TRADING - SEWING MACHINE - CONSUMABLE AND PACKAGING.

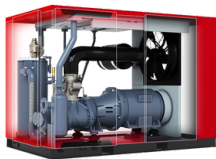


TABLE OF CONTENTS

2 ABOUT US



SUMBER ARTHO INDORAYA



OUR GOALS 3



4 CUSTOMER TARGET



OUR EXPERIENCE 5



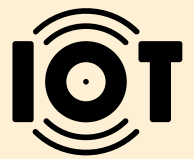
14 OUR PARTNERS





SUMBER ARTHO INDORAYA :

PT. Sumber Artho Indoraya (SAI) is a company that has been operating since January 2020, Our company focuses on mechanical and electrical general contractor for the industrial installation sector, monitoring and instrument control systems to save energy with a focus on CO2 reduction. General trading PT Sumber Artho Indoraya has several authorized dealers for industrial needs including juki & jin sewing machines, suto, miura boiler and compressor Chicago Pneumatic.





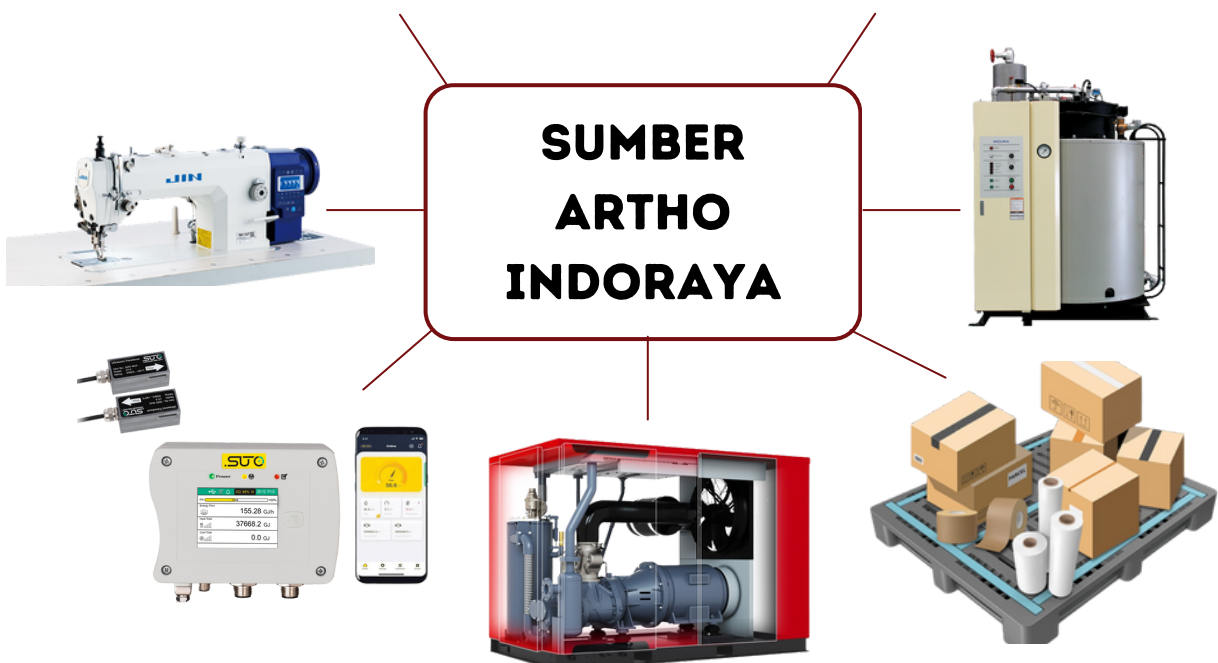
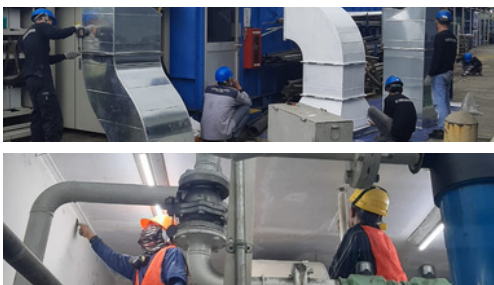
OUR GOALS

OUR VISION

To be a professional company that builds the best and trusted real sector jobs and social responsibility in the field of industrial.

OUR MISSION

- Adaptive and innovative in maintaining product quality and improving the quality of service
- Effective and efficient by implementing good corporate governance
- Making work safety number one in accordance with the operational standards of applicable procedures.





CUSTOMER TARGET



**CONSUMER
GOODS**



**MANUFACTURING
/ ELECTRONIC**



**GARMENT
INDUSTRY**

**PHARMACY
INDUSTRY**



**FOOD AND
BEVERAGE**



**TEXTILES
INDUSTRY**





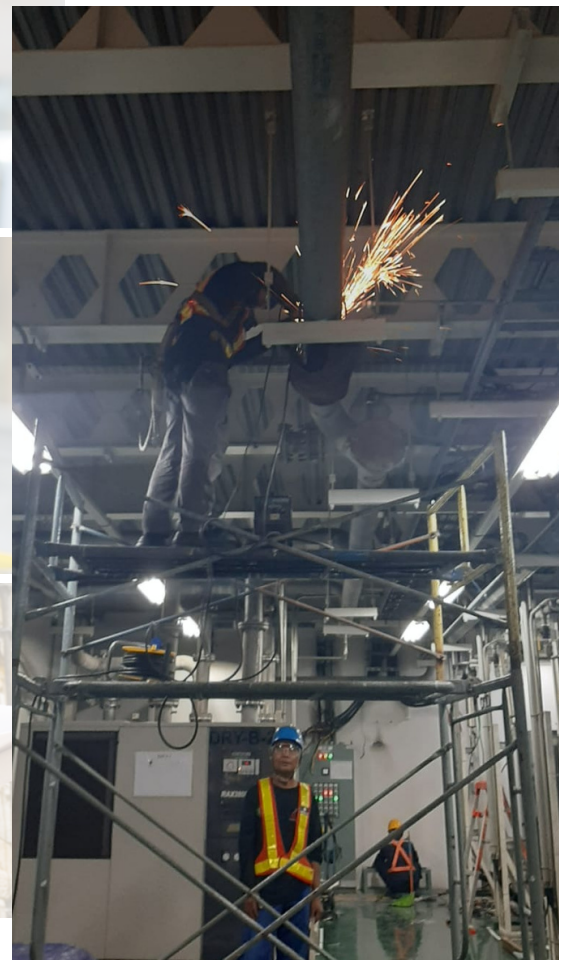
OUR EXPERIENCE

GENERAL CONTRACTOR

MECHANICAL & ELECTRICAL CONTRACTORS



Team of experienced engineers and technicians, our Mechanical & Electrical system is always committed to delivering the best results and services to every customer, prioritizing quality and competitive pricing. We specialize in the installation of utility machinery, such as air compressors, boilers, cooling towers, chillers, and panel maintenance.





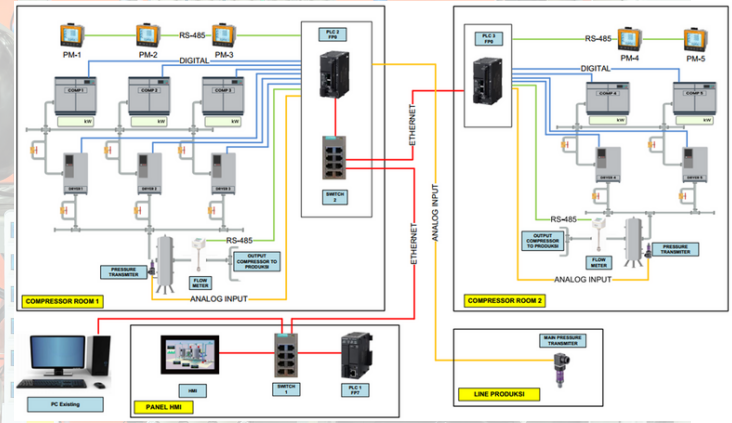
OUR EXPERIENCE

GENERAL CONTRACTOR

INSTRUMENT MONITORING & CONTROLLING SYSTEM

PT Sumber Artho Indoraya has also developed an IoT (Internet of Things) based monitoring and controlling technology system to implement the Industry 4.0 concept.

The system enables real-time monitoring and control of water, gas, liquid, and energy consumption, as well as report generation based on actual parameter data. The goal is to improve system efficiency to reduce CO2 emissions.



REAL TIME MONITOR

Start Cycle Time : 0 sec
Stop Cycle Time : 0 sec

Unit No.	Compressor		Dryer	
	Status	Alarm	Status	Alarm
1 75kW	Run Ready HMI	Fail Start Fail Stop Trip Mnt	Run HMI	Trip Mnt Fail Start
2 75kW	Run Ready HMI	Fail Start Fail Stop Trip Mnt	Run HMI	Trip Mnt Fail Start
3 160kW	Run Ready HMI	Fail Start Fail Stop Trip Mnt	Run HMI	Trip Mnt Fail Start
4 160kW	Run Ready HMI	Fail Start Fail Stop Trip Mnt	Run HMI	Trip Mnt Fail Start
5 160kW	Run Ready HMI	Fail Start Fail Stop Trip Mnt	Run HMI	Trip Mnt Fail Start

Main Pressure 0.000 Mpa | R1 Pressure 0.000 Mpa | R2 Pressure 0.000 Mpa | Low Pressure [RESET]

Graphic | AUTO | MANUAL



Be Smart. Measure It.



SUTO provides innovative and high-quality solutions in the fields of flow, pressure, temperature, humidity, and air quality measurement. SUTO iTEC products are used in various industries such as automotive, pharmaceutical, food and beverage, energy, and many more.

S401



THERMAL MASS FLOW

S120



OIL VAPOR MONITOR

S130



LASER PARTICLE COUNTER

S435



**VORTEX FLOW METER
FOR STEAM INLINE**

S418



**COMPACT THERMAL MASS
FLOW METER PRO-INLINE**

S600



**PORTABLE COMPRESSED AIR
PURITY ANALYZER**

S520



**PORTABLE DEW POINT
METER**

S531



**SMART ULTRASONIC
LEAK DETECTOR**

S461



**ULTRASONIC FLOW
METER FOR LIQUID**



Chicago Pneumatic



PT Sumber Artho Indoraya has established a partnership with Atlas Copco Group to become an agent of Chicago Pneumatic, focusing on compressors and dryers. We also provide support for unit sales (Oil Injected Screw & Oil Free Compressor), after-sales service, and maintenance of Chicago Pneumatic units.



**OIL-INJECTED SCREW
COMPRESSORS
4-37 kW**



**WISAIR
OIL-FREE COMPRESSORS
15-75 kW**



**SPIRALAIR
OIL-FREE COMPRESSORS
1,5-22 kW**



**OIL-INJECTED SCREW
COMPRESSORS
45-250 kW**



**REFRIGERANT DRYER
CPX 30-2650 50HZ, CPX 30-850 60HZ**



PT Sumber Artho Indoraya collaborates with PT Miura Indonesia, a specialist in boiler manufacturing. Miura focuses on boiler production with a commitment to energy efficiency and environmentally friendly technology, implementing the concept of Industry 4.0 through IoT-based "technoservice" technology.



SU SERIES
Mini-size Once-through Multi-tube Boiler

OIL FIRED

SU-160 SU-200 SU-300 SU-400



SI SERIES
Eco-Friendly NOx Boiler

OIL FIRED

SI-2000GVS SI-2500GVS



KX SERIES
Thermal Oil Boiler

OIL FIRED **GAS FIRED**

KX-8~80 KX-100~200



ME SERIES
Exhaust Gas Boiler

ELECTRIC TYPE

ME-10 ME-20 ME-30
ME-40 ME-50 ME-100



EI SERIES
Stable High Quality Steam Supply

GAS FIRED LOW NOX

OIL FIRED

GAS FIRED OIL FIRED

EI-1000GH EI-1000GS
EI-1500GH EI-1500GS



JUKI & JIN

PT Sumber Artho Indoraya, since 2022, has been committed to working with sewing machine brands from Japanese manufacturing, namely JUKI and JIN in Indonesia. JUKI is an industrial sewing machine manufacturer from Japan, prioritising quality and high technology.

The JIN brand is a second brand from JUKI, which has a display of "JUKI In-ternational.". JIN is committed to creating the best basic apparel and non-apparel sewing machines in its class to support medium-sized businesses.





CONSUMABLE AND PACKAGING PRODUCTS

As a trading company, we are here to supplied production needs in factories. For example, we can supply:



KERTAS GJA



STRETCH FILM



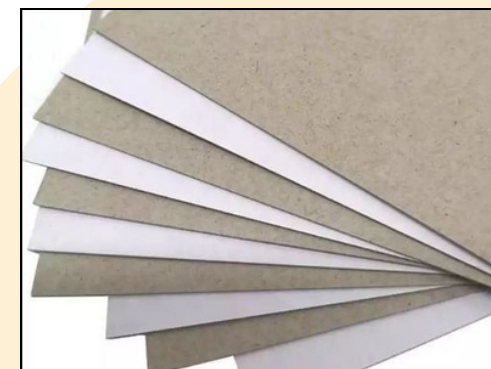
AMPLAS



ADHASIVE TAPE



PACKAGING BOX/KARDUS



DUPLEX

CONSUMABLE AND PACKAGING PRODUCTS



KERTAS ASPEK



KAIN DRI FIT



POLYFOAM



PALLET PLASTIK



SACK/KARUNG



SIKU PAPER



PP STRAPPING



SILICA GEL



CONTAINER BOX

CONSUMABLE AND PACKAGING PRODUCTS



KERTAS LITHO



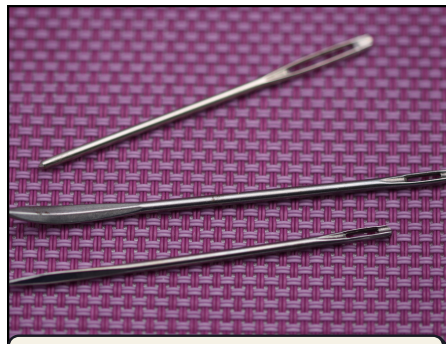
GLOVES



BUBBLE WRAP



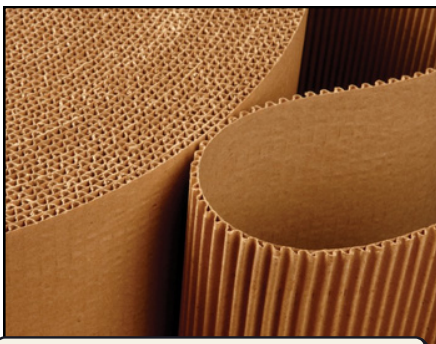
THREAD



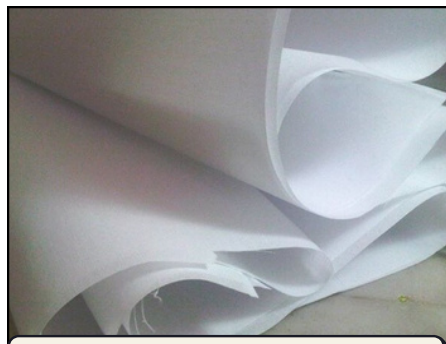
JARUM



PLASTIK HD



**KARTON
SINGLE FACE**



KAIN KERAS



KAIN MAJUN



OUR PARTNERS



The Dai Nippon Printing Group



PT. YKK ZIPCO INDONESIA



P.T AISAN NASMOCO INDUSTRI



new armada



For Safety Evolution



PT. Yamatogawa Indonesia



PT. SOO INDAH JAYA



PT. DATER GARMENT INDUSTRI



PT. HINI DAIKI INDONESIA



PT. TIJWULAN PUTRA MANDIRI



19 M.GEE 90

EveryWear



ALENDORS GLOBAL PRODUCTION



PT. SUMBER ARTHO INDORAYA



WORKSHOP



OFFICE



**ONE STOP
SOLUTION
IN EVERY NEED**

KONTAK KAMI :



OFFICE

: Jl. Pasir Jaya XII No.Ruko Kav.3, Pasirluyu, Kec. Regol, Kota Bandung, Jawa Barat 40254.



WORKSHOP

: Jl. Raya Kelapa Dua No.201. Pedurenan, Mustika Jaya, Kota Bekasi.



**: 022-4283-5881
0882-0000-41320**



: info@saindo.id